

東芝照明器具配光データシート

名称	蛍光灯器具
形名	FHT-21007-D AH

保守率	良	0.73
	中	0.69
	否	0.61

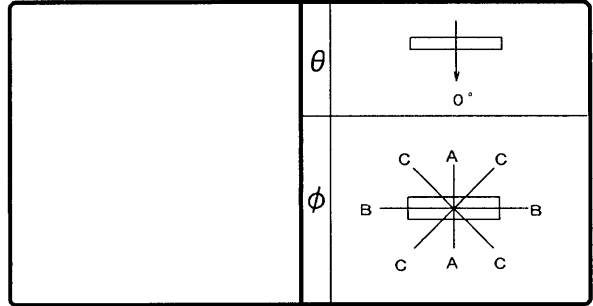

光源	名称	蛍光ランプ
	形名	FHF16EX-N-H
	光束	2100 lm × 1

効率	F \cap	22%
	F \cup	70%
	F \circ	92%
	器具光束	1934 lm

最大取付間隔	
A-A	1.6 H
B-B	1.3 H

備考	
----	--

前面	
反射面	塗装 (白)

光度 (cd/1000lm)			
$\theta \setminus \phi$	A-A	B-B	C-C
0°	151	151	151
10°	149	150	152
20°	151	141	149
30°	153	128	144
40°	155	109	137
50°	155	87	130
60°	151	63	121
70°	141	37	107
80°	126	15	88
90°	118	0	79
100°	120	0	81
110°	111	0	62
120°	77	0	32
130°	40	0	11
140°	9	0	1
150°	0	0	0
160°	0	0	0
170°	0	0	0
180°	0	0	0

反射率 (%)	天井	80						70						50						30		20		0	
	壁	70		50		30		70		50		30		50		30		30		10		0			
	床	30	10	30	10	30	10	30	10	30	10	30	10	30	10	30	10	30	10	30	10	10	0		
室指数	照明率 (×0.01)																								
0.60	49	45	35	34	27	26	46	43	34	32	26	25	31	29	24	23	22	21	17	14					
0.80	59	53	45	42	36	34	55	51	43	40	34	33	38	37	31	30	29	28	23	20					
1.00	65	58	51	47	42	40	61	55	49	45	40	38	44	41	37	35	33	32	27	24					
1.25	72	64	58	54	49	46	67	61	55	51	47	44	50	47	42	41	38	37	32	28					
1.50	77	67	64	58	54	50	72	64	60	55	52	48	54	50	47	44	42	41	35	31					
2.00	84	73	73	65	63	58	79	70	68	62	60	56	61	57	54	51	49	47	42	37					
2.50	89	76	78	69	69	63	83	73	74	66	66	60	65	60	59	55	53	51	46	41					
3.00	92	79	83	72	74	66	86	75	78	69	71	64	69	63	63	59	57	54	49	44					
4.00	97	82	89	77	82	72	90	79	83	74	77	69	74	67	69	64	61	58	53	48					
5.00	100	84	93	79	86	75	93	81	87	76	81	72	77	70	72	67	64	61	56	51					
10.00	106	89	102	86	98	83	99	85	96	82	92	80	84	76	81	74	72	68	64	58					

